**Special tools required:**

- 26 1 040

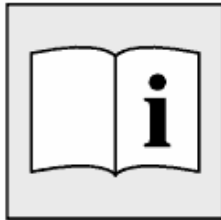

Remove complete exhaust system.

E36 / S54 (Z3):

Remove catalytic converter with center muffler.

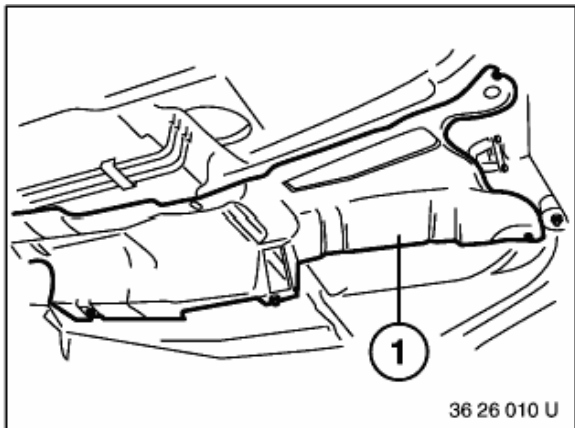

Remove heat shield (1).

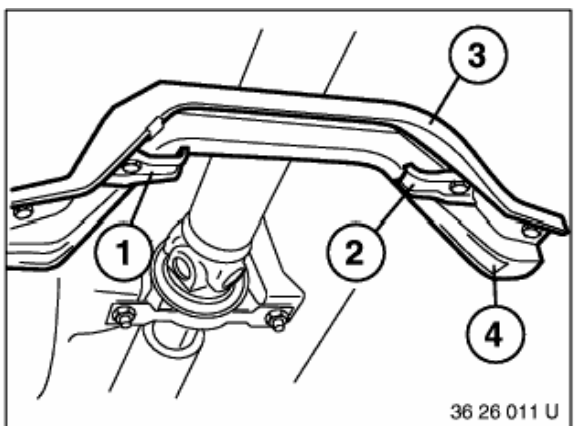

Remove bracket (1 and 2) for exhaust suspension.

Remove bar (3).

Installation:

Install bar (3) with long collar (4) towards front.

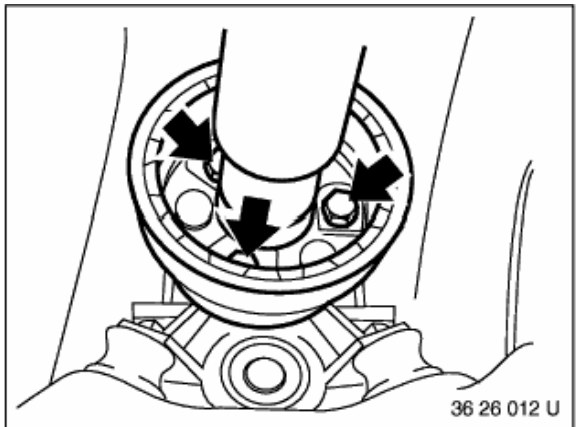

Version with flexible disk:

Remove flexible disk from transmission.

Release nuts.

Tightening torque, 26 11 1AZ.

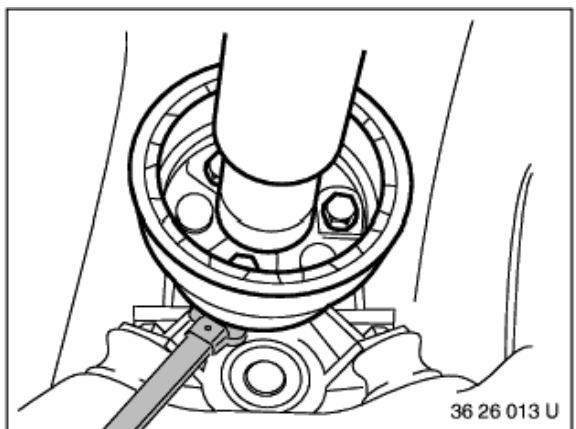

Installation:

Replace self-locking nuts.

Tighten screw connection by way of nut.

To prevent subjecting flexible disk to torsion stress, only turn nuts/screws on flange side.

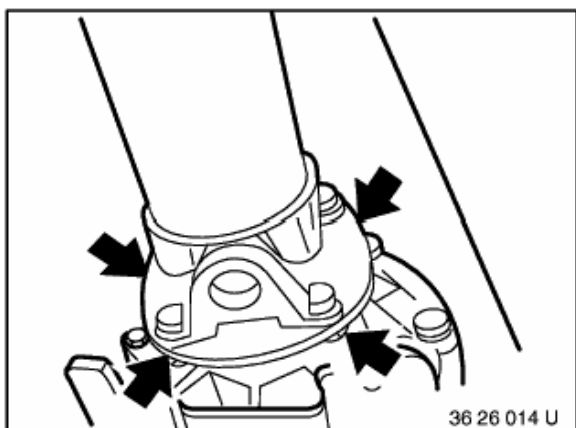

Version with universal joint:

Remove universal joint from transmission.

Release nuts.

Tightening torque, 26 11 2AZ.

Installation:

Replace self-locking nuts.

Tighten screw connection by way of nut.

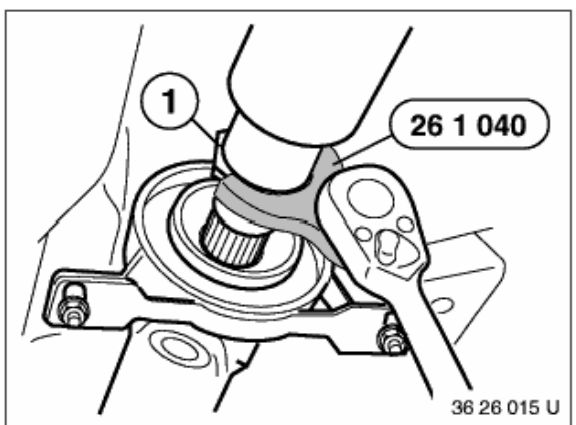

Release threaded sleeve (1) several turns with special tool 26 1 040 .

Tightening torque, 26 11 3AZ.

Installation:

After completing installation, tighten threaded sleeve with special tool 26 1 040 .

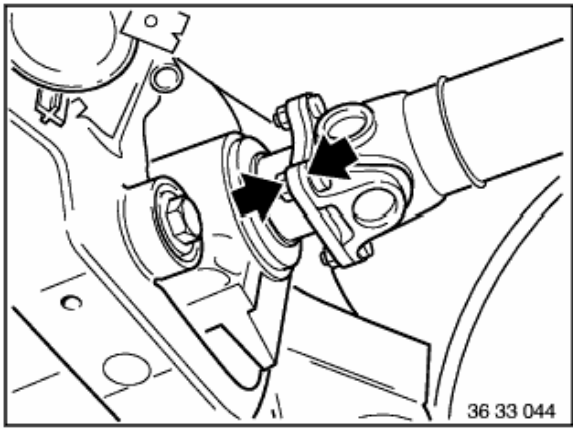

Caution!

Removal of propeller shaft: Mark universal joint to drive flange of rear axle.

This will eliminate complaints of droning.

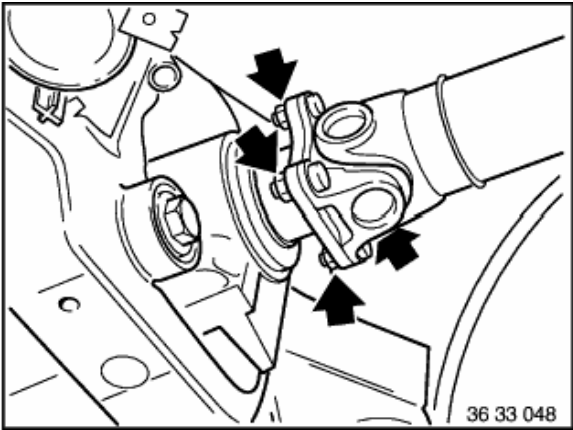

Remove universal joint from final drive.

Release nuts.

Tightening torque, 26 11 4AZ.

Installation:

Replace self-locking nuts.

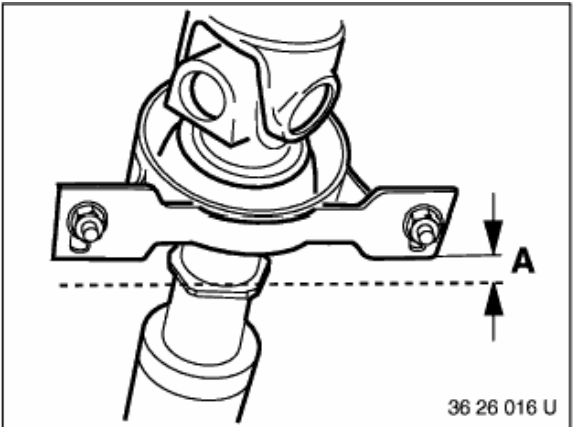

Grip propeller shaft at center mount and release nuts.

Tightening torque 26 11 6AZ.

Installation:

Pretension center mounts in direction of travel 4 ... 6 mm (A).

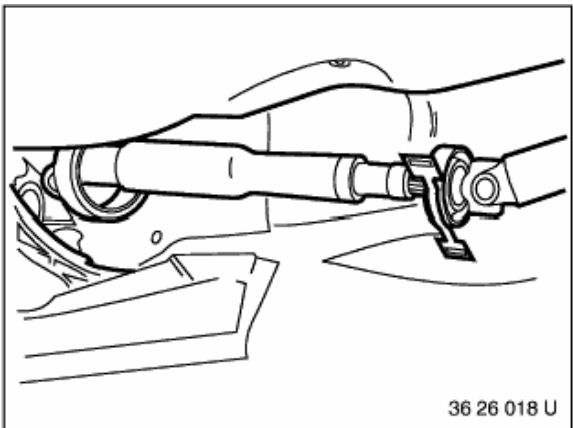

Bend propeller shaft downwards at center mount and in so doing detach centering mount on manual transmission/universal joint from final drive.

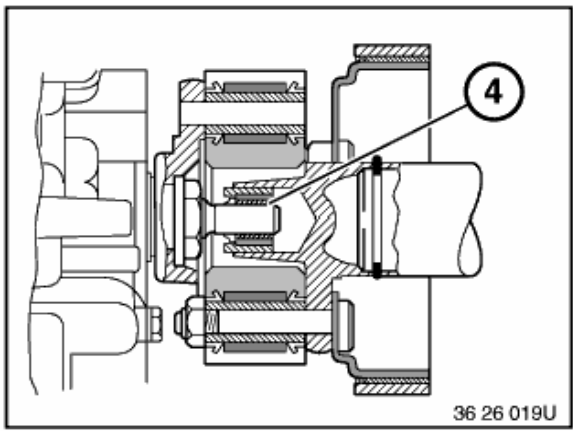

Installation:

Check centering mount (4).

Replace a damaged centering mount.

Coat centering mount with Molykote Longterm 2 grease,
refer to BMW Parts Service.